



# **T** ELENOR

# **S** PECIFICATION

Specification no.: OA 406  
Edition: 5.1  
In force from: 01.11.2010

---

## **Requirements for equipment to be connected to the local sub-loop in the access network of Telenor. Equipment providing VDSL or VDSL2 and PSTN or ISDN Basic Access services, shared access (service type F<sub>DD</sub>)**

---

**Document ID** : TNO-FX-PT-I&P/OA406/0111 2010  
**Archive no.** :  
**Index words** : Access network, copper pairs, LLUB, equipment requirements, VDSL, VDSL2  
**Abstract** : Requirements for the equipment of an Operator leasing copper pairs in the access network of Telenor in order to provide VDSL services

Telenor  
N-1331 Fornebu, Norway  
Telephone: +47 810 77 000

# TELENOR SPECIFICATION

Specification  
OA 406

Requirements for equipment to be connected to the local sub-loop in the access network of Telenor. Equipment providing VDSL or VDSL2 and PSTN or ISDN Basic Access services, shared access (service type F<sub>DD</sub>)

Date: 01.11.2010

Edition: 5.1

Page: 2 of 11

## CONTENT

<b>1</b>	<b>SCOPE</b> .....	<b>3</b>
<b>2</b>	<b>REFERENCES</b> .....	<b>3</b>
2.1	NORMATIVE REFERENCES.....	3
2.2	INFORMATIVE REFERENCES .....	4
<b>3</b>	<b>DEFINITIONS AND ABBREVIATIONS</b> .....	<b>4</b>
<b>4</b>	<b>APPLICATION</b> .....	<b>5</b>
<b>5</b>	<b>GENERAL REQUIREMENTS</b> .....	<b>5</b>
<b>6</b>	<b>TRANSMISSION SYSTEM</b> .....	<b>5</b>
6.1	USE OF FREQUENCY BANDS FOR THE VDSL TRANSCEIVERS .....	6
6.1.1	<i>Multi-carrier modulation method of VDSL transceivers</i> .....	6
6.2	REQUIREMENTS FOR A BASE-BAND PSTN SERVICE .....	6
6.3	REQUIREMENTS FOR A BASE-BAND ISDN BASIC ACCESS SERVICE.....	6
<b>7</b>	<b>ELECTRICAL CHARACTERISTICS</b> .....	<b>6</b>
7.1	REMOTE FEEDING .....	6
7.2	TRANSMITTER/RECEIVER IMPEDANCE AND RETURN LOSS .....	7
7.3	TRANSMIT SPECTRAL MASKS.....	7
7.3.1	<i>Transmit spectral mask of VTU-O</i> .....	7
7.3.2	<i>Transmit spectral mask of VTU-R (gjenstår å oppdatere for DPBO)</i> .....	7
7.4	WIDEBAND LAUNCH POWER.....	8
7.5	UNBALANCE ABOUT EARTH, TRANSMITTER/RECEIVER .....	8
7.6	REQUIREMENTS FOR UNIVERSAL SPLITTER, ISDN / PSTN .....	8

### Annex 1: Document history

### Annex 2: Statement of Compliance

<b>TELENOR SPECIFICATION</b>		
<b>Specification</b> OA 406	<b>Requirements for equipment to be connected to the local sub-loop in the access network of Telenor. Equipment providing VDSL or VDSL2 and PSTN or ISDN Basic Access services, shared access (service type F<sub>DD</sub>)</b>	
<b>Date:</b> 01.11.2010	<b>Edition:</b> 5.1	<b>Page:</b> 3 of 11

## 1 Scope

This specification gives requirements for equipment owned by Operator intended for connection to copper pairs in the access network of Telenor. The requirements apply for equipment supplying VDSL or VDSL2 on one copper pair and facilities to support PSTN or ISDN Basic Access (BA) services on the same copper pair. A splitter shall be provided at each end of the copper pair.

The Operator is responsible that the equipment is in conformance to this specification.

For equipment to be installed in Teleosji the formulary 'Statement of Compliance' in annex 2 shall be completed and forwarded to Telenor.

## 2 References

This specification incorporates by dated or undated references, provisions from other publications/standards. These normative references are cited at the appropriate places in the text and the references are listed hereafter. For dated references, subsequent amendments to or revisions of any of these publications apply to this specification only when incorporated in it by amendment or revision. For undated references, including amendments, the last edition of the document referred to applies.

### 2.1 Normative references

- [1] ITU-T Recommendation G.993.2 Very high speed digital subscriber line transceivers 2 (VDSL2)
- [2] ETSI TS 101270-1 V1.4.1 (2005-10): "*Transmission and Multiplexing (TM); Access transmission systems on metallic access cables; Very high speed Digital Subscriber Line (VDSL); Part 1: Functional requirements*"
- [3] ETSI TS 101270-2 V1.2.1 (2003-07): "*Transmission and Multiplexing (TM); Access transmission systems on metallic access cables; Very high speed Digital Subscriber Line (VDSL); Part 2: Transceiver specification*"
- [4] ETSI TS 101 952-2-1 V1.1.1 (2002-11) "Access network xDSL transmission filters; Part 2: VDSL splitters for European deployment; Sub-part 1: Specification of the low pass part of VDSL/POTS splitters"
- [5] ETSI TS 101 952-2-2 V1.1.1 (2003-03) Access network xDSL transmission filters; Part 2: VDSL splitters for European deployment; Sub-part 2: Specification of the high pass part of VDSL/POTS splitters for use at the Local Exchange (LE) and the user side near the Network Termination Point (NTP)"
- [6] ETSI TS 101 952-2-3 V1.1.1 (2003-03): "Access network xDSL transmission filters; Part 2: VDSL splitters for European deployment; Sub-part 3: Specification of VDSL/ISDN splitters for use at the Local Exchange (LE) and the user side near the Network Termination Port (NTP)"
- [7] Telenor Specification OA 100: "*General requirements for equipment to be connected to*

# TELENOR SPECIFICATION

Specification  
OA 406

Requirements for equipment to be connected to the local sub-loop in the access network of Telenor. Equipment providing VDSL or VDSL2 and PSTN or ISDN Basic Access services, shared access (service type F<sub>DD</sub>)

Date: 01.11.2010

Edition: 5.1

Page: 4 of 11

*the local loop in the access network of Telenor and/or material and equipment to be installed and operated in Telelosji”*

- [8] Telenor Specification OA 101: “*Requirements for equipment to be connected to the local loop in the access network of Telenor. Equipment providing PSTN services, full unbundled access (service type A<sub>AF</sub>)”*
- [9] Telenor Specification OA 102: “*Requirements for equipment to be connected to the local loop in the access network of Telenor. Equipment providing ISDN Basic Access services or 160 kbit/s digital transmission, full unbundled access (service type B<sub>AF</sub>)”*
- [10] Telenor Specification OA 206: “*Requirements for equipment to be connected to the local loop in the access network of Telenor. Equipment providing VDSL and PSTN or ISDN Basic Access services, shared access (service type F<sub>AD</sub>)”*

## 2.2 Informative references

- [11] Telenor Specification OA 106: “*Requirements for equipment to be connected to the local loop in the access network of Telenor. Equipment providing VDSL and PSTN or ISDN Basic Access services, full unbundled access (service type F<sub>AD</sub>)”*
- [12] Telenor Specification OA 306: “*Requirements for equipment to be connected to the local sub-loop in the access network of Telenor. Equipment providing VDSL and PSTN or ISDN Basic Access services, full unbundled access (service type F<sub>DF</sub>)”*
- [13] Telenor Nett Specification A59 (2001-05): “*Access to copper pairs in the access network of Telenor. Specification of the network side of the user-network interface”*
- [14] Draft ETSI TS 101 952-2 V1.0.6 (2010-02): “*Access network xDSL splitters for European deployment; Part 2: Generic specification of xDSL over ISDN splitters and xDSL universal splitters. This specification will replace [4] to [6] as soon it is published (summer 2010)*

## 3 Definitions and abbreviations

Telelosji	Colocation at the premises of Telenor
Operatøraksess	Operators’ access to the access network of Telenor
ADSL	Asymmetric Digital Subscriber Line
DPBO	Downstream Power Back Off
DMT	Discrete Multi-Tone
SCM	Single Carrier Multiplexing
DB	Distribution Box
MDF	Main Distribution Frame
NTP	Network Termination Point
NTU	Network Termination Unit

<b>TELENOR SPECIFICATION</b>		
<b>Specification OA 406</b>	<b>Requirements for equipment to be connected to the local sub-loop in the access network of Telenor. Equipment providing VDSL or VDSL2 and PSTN or ISDN Basic Access services, shared access (service type F<sub>DD</sub>)</b>	
<b>Date: 01.11.2010</b>	<b>Edition: 5.1</b>	<b>Page: 5 of 11</b>

UPBO	Upstream Power Back Off
VDSL	Very high-speed Digital Subscriber Line
VTU-O	VDSL transceiver unit located at telecommunication centre
VTU-R	VDSL transceiver unit at subscriber

## 4 Application

This specification applies to a VDSL systems provided by an Operator. The VDSL access node and the local splitter are placed in the vicinity of a distribution box (DB) and the VDSL transceiver unit (VTU-R) at the subscriber's premises as shown in figure 1. Internal connections and cables within the distribution box owned by Telenor must be established by use of the Telelosji service (co-location).

The Operator shall provide for one splitter at the VDSL transceiver in the vicinity of the DB of Telenor and one splitter at NTP. The two splitters shall allow for transmission of both PSTN and ISDN basic access, but only one service will be connected at the same time. The low frequency entrance to the splitter located in the vicinity of the DB shall be present at the DB.

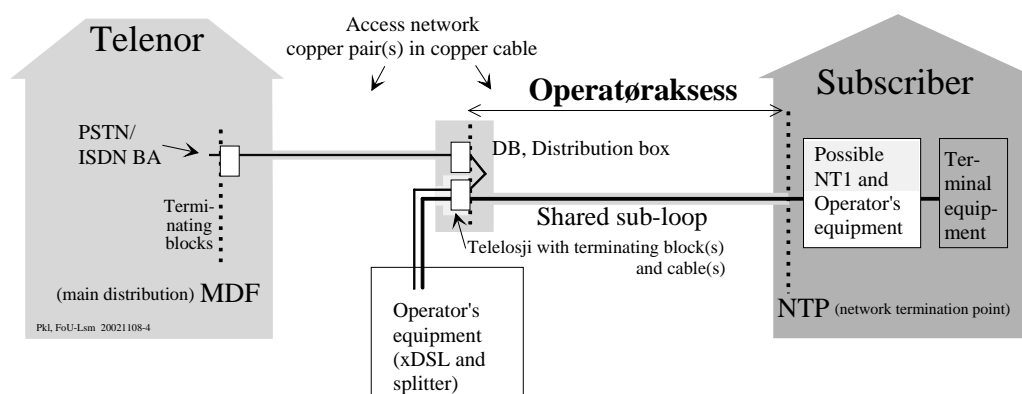

**Figure 1 Configuration of the access network.**

## 5 General requirements

All installed equipment operating in Telelosji or used for Operatøraksess shall fulfill requirements stated in Telenor Specification OA 100 [7] related to:

- Safety
- Environmental conditions
- Documentation.

## 6 Transmission system

The transmission system shall be based on ITU-T G.993.2 [1]. The transmission method of the VDSL transceivers utilizes a frequency division multiplex for simplex transmission in separate frequency windows. Moreover the lowest frequency band may be used either for

<b>TELENOR SPECIFICATION</b>		
<b>Specification OA 406</b>	<b>Requirements for equipment to be connected to the local sub-loop in the access network of Telenor. Equipment providing VDSL or VDSL2 and PSTN or ISDN Basic Access services, shared access (service type F<sub>DD</sub>)</b>	
<b>Date: 01.11.2010</b>	<b>Edition: 5.1</b>	<b>Page: 6 of 11</b>

PSTN (see 6.2) or for ISDN basic access (see 6.3).

## 6.1 Use of frequency bands for the VDSL transceivers

The band plans to be applied to the access network of Telenor Norway is defined according to ITU-T G.993.2 Annex B (European specifications) with a specific frequency range defined by frequency plan 998.

The frequency usage should be allocated as:

\*) If 17MHz bandplan is implemented upper band edge of DS3 is 17664 kHz

Direction: VTU-O to VTU-R	
DS1	2208 – 3750 kHz
DS2	5200 – 8500 kHz
DS3	120000 – 24890 kHz *)
Direction: VTU-R to VTU-O	
US0	120 – 276 kHz
US1	3750 – 5200 kHz
US2	8500 – 12000 kHz
US3	24890 – 30000 kHz

**Table 6.1** Frequency bands for VDSL transceivers.

### 6.1.1 Multi-carrier modulation method of VDSL transceivers

ITU-T G993.2 clause 10, details a transmission method utilizing many carriers with a spacing of 4,3125 kHz in each frequency band (8,625 kHz for some profiles).

## 6.2 Requirements for a base-band PSTN service

The requirements given in Telenor Specification OA 101 [8] apply. The requirements apply at the interface between the splitter and the copper cable of Telenor. The splitter used shall comply with requirements in clause 7.6.

## 6.3 Requirements for a base-band ISDN basic access service

The requirements given in Telenor Specification OA 102 [9] apply. The requirements apply at the interface between the equipment and the splitter. The splitter shall comply with the requirements given in clause 7.6.

# 7 Electrical characteristics

## 7.1 Remote feeding

Remote feeding of the VDSL equipment at the subscriber's premises is not allowed. (Remote feeding is reserved for PSTN/ISDN.)

<b>TELENOR SPECIFICATION</b>		
<b>Specification OA 406</b>	<b>Requirements for equipment to be connected to the local sub-loop in the access network of Telenor. Equipment providing VDSL or VDSL2 and PSTN or ISDN Basic Access services, shared access (service type F<sub>DD</sub>)</b>	
<b>Date: 01.11.2010</b>	<b>Edition: 5.1</b>	<b>Page: 7 of 11</b>

## 7.2 Transmitter/receiver impedance and return loss

A reference impedance according to ETSI TS 101270-1 [2], sub-clause 8.1.1, shall be used to measure the return loss of the VDSL modem. The return loss shall be at least 12 dB for all VDSL frequencies (refer to ETSI TS 101270-1 [2], sub-clause 8.1.2) when separate (successive) measurements are done with both:

- 135 ohms
- 100 ohms.

For a limited period the requirements may be accepted with qualified measurements done only with 135 ohms reference.

## 7.3 Transmit spectral masks

Transmit spectral masks are given in 7.3.1 and 7.3.2.

The frequency domain used for VDSL2 overlaps with some of the frequency bands allocated for amateur radio. Information is given in ITU-T G.993.2 [1]. Any observed and conflicting electromagnetic interference originating from VDSL systems – most likely to be present where aerial cables are deployed – should be brought to Telenor's attention.

### 7.3.1 Transmit spectral mask of VTU-O

The transmit mask for VTU-O shall comply with ITU-T G.993.2 [1] Table B-7 – optional PSD-mask B8-2, B8-3, B8-6, B8-10, B8-12 and B8-15 is only allowed in the frequency area above 2208 kHz. **Be aware, no downstream PSD is allowed in the frequency area below 2208 kHz in sub-loop implementations.**

Downstream power back-off (DPBO) is for further considerations.

### 7.3.2 Transmit spectral mask of VTU-R (gjenstår å oppdatere for DPBO)

The transmit mask for VTU-R shall comply with ITU-T G.993.2 [1] Table B-7 – optional PSD-mask B8-2, B8-3, B8-6, B8-10, B8-12 and B8-15.

Upstream power back-off (UPBO) shall be enabled and performed by the VTU-R to improve spectral compatibility between VDSL2 systems on loops of different lengths deployed in the same binder according to the Power back-off mechanism procedure defined in ITU-T G.993.2 [1], sub-clause 7.2.1.3.

Two methods for upstream power back-off methods are defined:

- the Reference PSD UPBO method
- the Equalized FEXT UPBO method (optional)

The equalized FEXT UPBO method is for further considerations.

The Alien crosstalk profile referred as ETSI C as defined by ETSI TS 101 270 [2] sub-clause 8.1.6.1 Table 13 shall be used.

<b>TELENOR SPECIFICATION</b>		
<b>Specification OA 406</b>	<b>Requirements for equipment to be connected to the local sub-loop in the access network of Telenor. Equipment providing VDSL or VDSL2 and PSTN or ISDN Basic Access services, shared access (service type F<sub>DD</sub>)</b>	
<b>Date: 01.11.2010</b>	<b>Edition: 5.1</b>	<b>Page: 8 of 11</b>

The following values of  $a$  and  $b$  are set for spectrum profile definition,

dBm/Hz	$a$	$b$
US0	40	0
US1	47,3	21,14
US2	54	16,29
US3	56,5	6,3

**Table 7-1 UBPO PSD references**

Note: Values for US0 and US3 are for further consideration.

#### **7.4 Wideband launch power**

The wideband launch power of VTU-O and for VTU-R shall comply with ITU-T G.993.2 [1] Table 6-1 – VDSL2 profile defined by 8d, 8c, 12a, 12b, 17a and 30a, +14.5 dBm.

#### **7.5 Unbalance about earth, transmitter/receiver**

The unbalance about earth, measured as longitudinal conversion loss (LCTL), shall be in accordance with ETSI TS 101270-1 [2], sub-clause 8.1.3.

#### **7.6 Requirements for universal splitter, ISDN / PSTN**

The splitter shall be in accordance with ETSI TS 101 952-2-1 to 3 [4] - [6].



Telenor  
N-1331 Fornebu Norway  
Telephone: +47 810 77 000

<b>TELENOR SPECIFICATION</b>			
<b>Specification OA 406</b>	<b>Requirements for equipment to be connected to the local sub-loop in the access network of Telenor. Equipment providing VDSL or VDSL2 and PSTN or ISDN Basic Access services, shared access (service type F<sub>DD</sub>)</b>		
<b>Date:</b> 01.11 2010	<b>Edition:</b> 5.1	<b>Annex 1</b>	<b>Page: 1</b>

### Annex 1: Document history

Edition	Published	Comments
1.0	01.07.26	First interim version
1.2	01.11.01	Kjell E. Sterten, TTS-NL-I-P
2.0	01.02.02	Kjell E. Sterten, TTS-NL-I-P
3.0	31.12.02	Jon Weberg, NL-I-AN
4.0	01.01 2004	Kjell E. Sterten, TN-NL-U-T
4.1	01.05 2004	Kjell E. Sterten, TN-NL-U-T
4.2	01.01 2005	Heidi Eide, TN-SMP
4.3	01.03 2005	Kjell E. Sterten, TN-NL-U-T
4.4	31.10 2005	Kjell E. Sterten, TNO-FX-PT-I&P
5.0	01.07 2007	Vidar Skovli, TNO-FX-BBP/A
5.1	26.08 2010	Vidar Skovli, SIT

## STATEMENT OF COMPLIANCE

**TELENOR  
Specification OA 406**

**Requirements for equipment to be connected to the local sub-loop in the access network of Telenor. Equipment providing VDSL or VDSL2 and PSTN or ISDN Basic Access services, shared access (service type F<sub>DD</sub>)**

**Date: 01.11 2010**

**Edition: 5.1**

**Annex 2**

**Page: 1**

Date: \_\_\_\_\_ Operator: \_\_\_\_\_

System identification (vendor, model, type): \_\_\_\_\_

Connection to the access network of Telenor: Yes (direct) .....  Indirect (aux. equip.) .....

The given information is valid. Date/Signature: \_\_\_\_\_

(sign.)

FC = Fully compliant    NC = Non-compliance

Clause no.	Description	Statement of Compliance		Remarks and additional information	For internal use
		FC	NC		
<b>1</b>	<b>Scope</b>	<input type="checkbox"/>	<input type="checkbox"/>		
<b>2</b>	<b>References</b>				
2.1	Normative references	<input type="checkbox"/>	<input type="checkbox"/>		
2.2	Informative references	<input type="checkbox"/>	<input type="checkbox"/>		
<b>3</b>	<b>Definitions and abbreviations</b>	<input type="checkbox"/>	<input type="checkbox"/>		
<b>4</b>	<b>Application</b>	<input type="checkbox"/>	<input type="checkbox"/>		
<b>5</b>	<b>General requirements</b>	<input type="checkbox"/>	<input type="checkbox"/>		
<b>6</b>	<b>Transmission system</b>	<input type="checkbox"/>	<input type="checkbox"/>		
6.1	Use of frequency bands for the VDSL transceivers	<input type="checkbox"/>	<input type="checkbox"/>		
6.1.1	Multi-carrier modulation method of VDSL transceivers	<input type="checkbox"/>	<input type="checkbox"/>		
6.1.2	Single-carrier modulation method of VDSL transceivers	<input type="checkbox"/>	<input type="checkbox"/>		
6.2	Requirements for a base-band PSTN service	<input type="checkbox"/>	<input type="checkbox"/>		
6.3	Requirements for a base-band ISDN basic access service	<input type="checkbox"/>	<input type="checkbox"/>		
<b>7</b>	<b>Electrical characteristics</b>				
7.1	Remote feeding	<input type="checkbox"/>	<input type="checkbox"/>		
7.2	Transmitter/receiver impedance and return loss	<input type="checkbox"/>	<input type="checkbox"/>		
7.3	Transmit spectral masks	<input type="checkbox"/>	<input type="checkbox"/>		
7.3.1	Transmit spectral mask of VTU-O	<input type="checkbox"/>	<input type="checkbox"/>		
7.3.2	Transmit spectral mask of VTU-R	<input type="checkbox"/>	<input type="checkbox"/>		
7.4	Wideband launch power	<input type="checkbox"/>	<input type="checkbox"/>		
7.5	Unbalance about earth, transmitter/receiver	<input type="checkbox"/>	<input type="checkbox"/>		
7.6	Requirements for universal splitter, ISDN / PSTN (integrated or external)	<input type="checkbox"/>	<input type="checkbox"/>		

## UPBO PSD-MASK LIMITS

**TELENOR**  
**Specification OA 406**

**Requirements for equipment to be connected to the local sub-loop in the access network of Telenor. Equipment providing VDSL or VDSL2 and PSTN or ISDN Basic Access services, shared access (service type F<sub>DD</sub>)**

**Date: 01.11 2010**

**Edition: 5.1**

**Annex 3**

**Page: 2**

UPBOMASK us	U1		U2		U3	
998ADE Breakpoints (MHz)	3,75	5,2	8,5	12	25	30
Electrical length dB at 1 MHz	(dBm/Hz)	(dBm/Hz)	(dBm/Hz)	(dBm/Hz)	(dBm/Hz)	(dBm/Hz)
0	-84,7	-92,0	-98,0	-110,4	-84,5	-91,0
1	-82,8	-89,7	-95,1	-106,5	-79,5	-85,2
2	-80,9	-87,4	-92,2	-102,6	-74,5	-79,4
3	-78,9	-85,2	-89,2	-98,6	-69,5	-73,6
4	-77,0	-82,9	-86,3	-94,7	-64,5	-67,9
5	-75,1	-80,6	-83,4	-90,7	-59,5	-62,1
6	-73,1	-78,3	-80,5	-86,8	-56,5	-56,5
7	-71,2	-76,0	-77,6	-82,9	-56,5	-56,5
8	-69,2	-73,8	-74,7	-78,9	-56,5	-56,5
9	-67,3	-71,5	-71,8	-75,0	-56,5	-56,5
10	-65,4	-69,2	-68,8	-71,1	-56,5	-56,5
11	-63,4	-66,9	-65,9	-67,1	-56,5	-56,5
12	-61,5	-64,6	-63,0	-63,2	-56,5	-56,5
13	-59,6	-62,4	-60,1	-59,2	-56,5	-56,5
14	-57,6	-60,1	-57,2	-55,5	-56,5	-56,5
15	-55,7	-57,8	-54,8	-55,5	-56,5	-56,5
16	-53,8	-55,5	-54,8	-55,5	-56,5	-56,5
17	-51,8	-53,2	-54,8	-55,5	-56,5	-56,5
18	-51,2	-52,7	-54,8	-55,5	-56,5	-56,5
19	-51,2	-52,7	-54,8	-55,5	-56,5	-56,5
20	-51,2	-52,7	-54,8	-55,5	-56,5	-56,5
21					-56,5	-56,5
...					-56,5	-56,5